

Screen filters



Advantages of screen filters

Screen filters are often used as a safety feature of an installation. All dirt particles above a certain size are captured.

Their purpose is twofold: to signal a problem in the upstream part of the installation, while protecting the downstream part of the installation.

Advantages of UDI screen filters:

UDI screen filters are available as in-line and as angle filters. This safety can be further increased by using a second inner filter.

The water is filtered from the outside to the inside. The filter cake is located on the outside of the filter element, and can easily be removed by hand.

The inner elements are equipped with a stainless-steel filter mesh, available in various perforations. The effective filtering area of the screen is 32-47%, depending on perforation applied.

Coating:

In preparation for the coating, the filters are provided with a special layer of zinc phosphate. This treatment ensures proper adhesion of the coating, and protects against rusting-through from the inside.

Subsequently, the polyester coating is applied electrostatically, both internally and externally, before being furnace-hardened. The entire process involves 7 steps, and results in a perfect coating with a thickness of approximately 120 microns.

Applications:

- All water intakes
- Cooling water systems
- Recirculation systems
- Water transport systems
- After media filters
- Before distribution systems
- Before sprinkler systems



Subject to modifications.
No liability accepted for errors or misprints

Model

- Angle model
- In-line model

Materials:

- Polyester-coated steel
- Neoprene rubbers
- PVC interior elements with stainless steel filter screen
Perforation: 75, 100, 130, 200, 300, 435, and 800 microns (other perforations upon request)

Technical specifications:

- Max pressure: 10 bar
- Working pressure: 8 bar
- Max operating temperature: 55°
- Ph 5-9 resistant
- Filter screen on the outside of the element

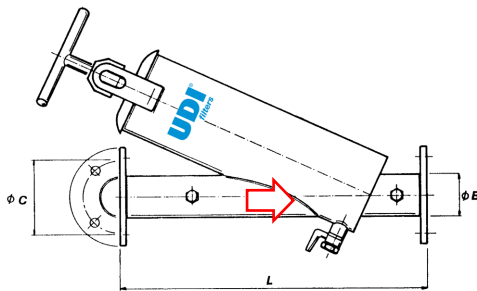

In-line (2000 series)

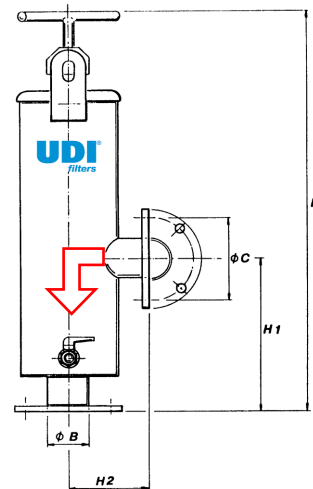

Angle (1000 series)

Type: angle	Unit	4U1015D	4U1020D	4U1020F	4U1030F	4U1040F
Connection Ø B	inch	1,5"	2"	2"	3"	4"
Capacity	m³/h	10 - 15	15 - 25	15 - 25	28 - 38	35 - 75
Flange (ISO 7005 PN10)		threaded	threaded			
Bolt circle diameter C	mm	-	-	125	160	180
Bolt holes	mm	-	-	4 x Ø18	8 x Ø18	8 x Ø18
H	mm	420	470	480	730	850
H1	mm	240	170	250	275	400
H2	mm	100	140	140	140	180
Weight	kg	6	13	16	22	32

Type: in-line	Unit	4U2020F	4U2030F	4U2040F	4U2260F	4U2280F
Connection Ø B	inch	2"	3"	4"	6"	8"
Capacity	m³/h	15 - 30	30 - 40	40 - 80	80 - 200	140 - 300
Flange (ISO 7005 PN10)						
Bolt circle diameter C	mm	125	160	180	240	295
Bolt holes	mm	4 x Ø18	8 x Ø18	8 x Ø18	8 x Ø22	8 x Ø22
Overall length L	mm	480	555	690	900	1110
Weight	kg	17	25	40	72	91