

Y Valve



Y Valve

The **Bermad** Y valves are hydraulically operated valves equipped with a diaphragm which can be doubly actuated. The Bermad 300 series Y valves are available in the sizes 1½", 2" and 3". The double control chamber enables a very wide range of applications in the installation for open/closed and control functions. The Y design of this valve has a very low pressure loss at high capacity.

The valve closes by increasing pressure on the upper diaphragm chamber. The lower diaphragm chamber is usually set to no pressure or is connected to the downstream side for slower closing. This chamber can in addition be pressurised for diverse applications. Water hammer is prevented by gradually opening and closing the valve.

Advantages:

- Insulated and protected diaphragm
- No water hammer
- Low pressure loss
- Practically unaffected by soiling

Specifications:

- Working pressure: 0,7 – 10 bar
- Max. temperature: 60 °C
- Connection: BSP female / flange
- Pressure class: ISO PN10

Materials:

- Body: 1½": nylon
2": brass (option: nickel-coated)
3": cast iron, polyester-coated
- Klephuis 1½": nylon and stainless steel
2": nylon, brass and stainless steel
3": nylon, brass and stainless steel
- Diaphragm: NR, nylon-fibre-reinforced
- Seals: NBR and NR



Subject to modifications
No liability accepted for errors or misprints



Y valve Technical data

Applications:

- Irrigation systems
- Sprinkler systems
- Industry
- Automation
- Recirculation systems
- Filter flushing valve
- Relief valve (safeguard)

Models:

- Hydraulic
- Electrical
- Pressure-reducing
- Pressure-reducing / electrical
- Pressure-regulating / relief valve

Dimensions and weights:

Model		1½" straight	2" straight	2" angled	3" straight thr.	3" straight fl.
Type		2U30015P1	2U30020Y1	2U30020H1	2U30030Y1	2U30030Y3
L	mm	112	124	71	210	235
H	mm	175	215	256	275	325
R	mm	30	40	75	58	98
Width	mm	105	125	135	160	200
Weight	kg	1,25	2	2,25	7,4	14,7
KV		32	53	60	108	108
CCDV	ltr	0,045	0,092	0,092	0,246	0,246

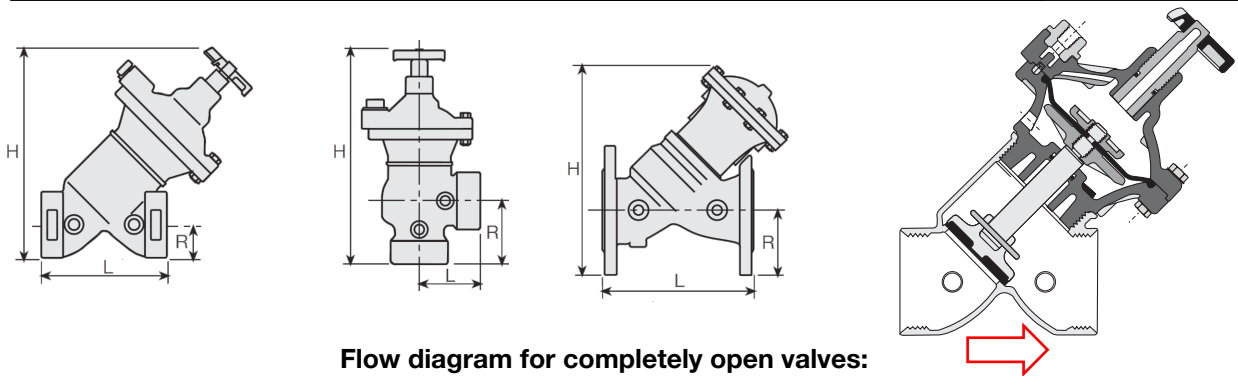

Flow diagram for completely open valves:

