

# Instruction Manual

## Screen Filter Series 1000/2000



### General instructions:

This filter has been designed and made to meet the highest requirements as to quality and finish. This filter is used especially as a control filter and is adapted to filter water containing small quantities of dirt/waste.

### Installation:

Series 1000: install the filter vertically.

Series 2000: install the filter horizontally the handle pointing upwards.

The water inlet and outlet are indicated by arrows.

The flush valve (09) must be located on the underside of the filter.

When installing more than one filter, allow enough room between the units for easier maintenance.

A pressure relief valve must be installed upstream of the filtering installation if the pressure is not sufficiently under control. If there is a risk of water flowing back, install a quick-acting (mechanical) check valve.

### Operation:

Normal operating conditions are achieved when the differential pressure across the clean filter element is less than 0.25 bar.

When the differential pressure exceeds 0.25 bar, then the filter is either partially soiled or it has to process too large a water flow.

The maximum working pressure is up to 8 bar.

The filter is designed to withstand a maximum pressure of 10 bar.

Check the differential pressure during operation by installing a pressure gauge (with needle) in the connection (18) in the filter inlet and outlet.

**Do not open the filter cover and do not tighten it while the filter is being used or under pressure!**

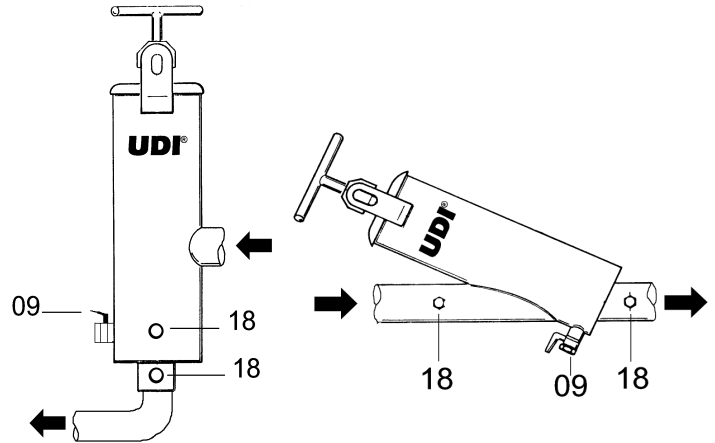

### Flushing:

Flushing can be easily carried out manually by opening the flush valve at the bottom of the filter.

Check the amount of time needed to reach a differential pressure of 0.4 bar.

Open the flush valve (09) and flush during 10-30 seconds.

Check the pressure: the differential pressure must be 0.25 bar or less.

Recommended filter cleaning and checking of the filter element: every 2 weeks or when the differential pressure is 1.0 bar or more.

### Periodic cleaning:

Stop the flow to the filter.

Open the flush valve (09) to let pressure and water escape.

Carefully remove the filter element (06) (also 05 if used).

Thoroughly clean the element with clean water, using a brush to remove dirt particles from the gauze (NEVER USE A STEEL WIRE BRUSH).

Keep the water level below the collar of the rubber so as to prevent soiled water from entering the system.

# Instruction Manual

## Screen Filter Series 1000/2000

**Assembly:**

Check the filter element for any damage.  
 Ensure that the inner rubber (07) is properly positioned, with the recess next to the valve (09).  
 Place the filter element(s) 06 (05) carefully back into the filter body.  
 Check whether the top of the filter element is flush with the top of the filter body.  
 Place the cover (03) on the filter body so that the cover rubber (04) fully covers the element(s) and is properly centred.  
 Place the tightening bracket (02) and fully tighten the handle (01).

**Parts drawing:**

When ordering, state the number of microns.  
 Note: Filters from model 1020 onwards can contain two elements.  
 In view of ongoing improvements, we reserve the right to change specifications without prior notice.

**Note:**

If the dirt particles cannot be removed from the element with a hair-fibre brush, dip the element into an acid/alkaline solution. Wait a few minutes for the solution to have its effect and then thoroughly clean the element.

**Maintenance:**

Each filter comes with these installation, operating and maintenance instructions.  
 Apply each year a film of grease on the thread of the spindle of the handle.  
 Avoid damage to the protective coating of the filter must be repaired immediately. Before applying the protective paint, the damaged spot must be cleaned properly using a steel wire brush.

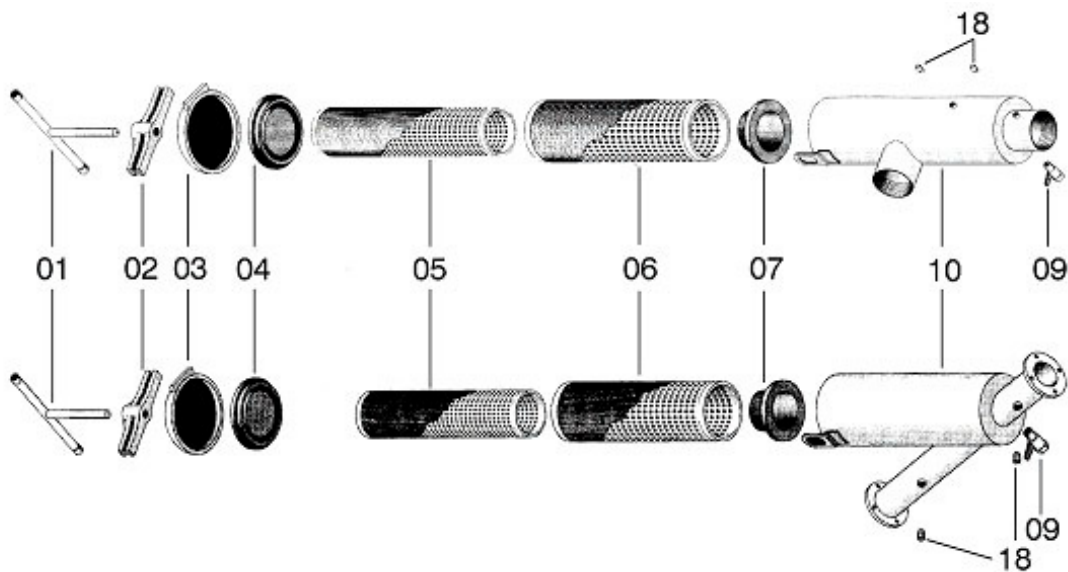

Type	Unit	1015D	1020D	1020F	1030D	1030F	2020F	2030D	2030F	2040F	2260F
<b>Connection Capacity</b>	Inch m <sup>3</sup> /h	1,5" 10-15	2" 15-25	2"-fl 15-25	3" 28-38	3"-fl 28-38	2"-fl 15-30	3" 30-40	3"-fl 30-40	4"-fl 40-80	6"-fl 80-200

