

Instruction Manual

Sand/media Filter Series 4000



General instructions:

This filter has been designed and made to meet the highest requirements as to quality and finish. This media filter uses sand (or gravel) as a filter bed and captures the suspended dirt/impurities from the water flowing through it. Media filters are especially suitable for the filtering of algae, organic matter and recycled water. Media filters (4000 Series) have an especially designed double bottom separated by a welded-in reinforced steel plate. This results in these filters being well adapted for effective backwashing.

Automatic backwashing is an option, even for a single filter.

For best results, the filter must be correctly installed and the backwash operation accurately set.

Working:

The unfiltered water is spread in the top section of the filter and drops slowly through the filter bed. The filter bed consists of sand, gravel or another filter medium. The small pores prevent the dirt particles from passing through, thus retaining them. During the backwash operation, the filter bed expands and the pores widen so that the (organic) dirt can escape. This is then discharged with the flushing water.

Installation:

Place the sand filter at the point of installation. Fit the valves and connect to the water system.

Pay particular attention to the correct direction of the water flow.

For automatic backwashing, preferably install a differential-pressure switch and (Bermad) backwash valve(s). Install pressure gauges to check the working pressure and to be able to determine the differential pressure.

Check to ensure the mushroom diffusers and manholes are properly mounted.

Charge the filter through the filling hole with sand not higher than to the level indicated, and spread the sand evenly in the filter.

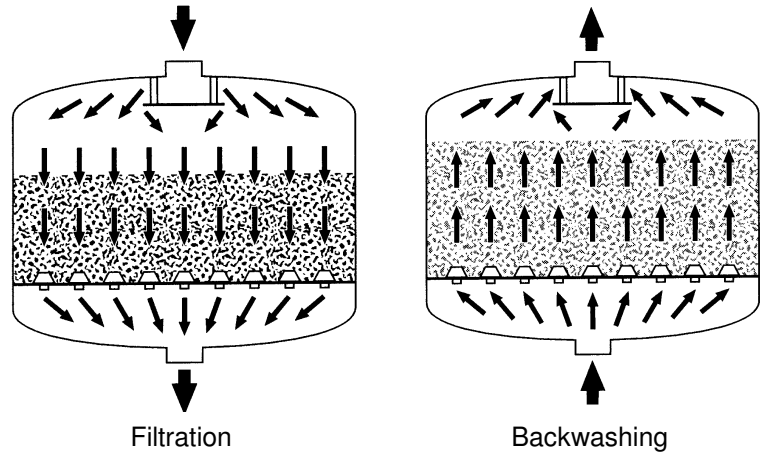

For effective filtration, the filter media should have crushed, sharp edges (minimum grain size of medium: 0.4 mm). Close the filling hole with the cover. Carefully place the bridge and spindle with handle, and secure the cover.

Fill up the filter with water from below. Ensure that all service covers, valves and accessories are properly sealed. Check for leaks.

Backwash the filter containing the new charge in order to wash out impurities, dust and fine matter for at least 2 minutes.

Reduce the flow from the flush valve to the extent that during the backwash operation no sand will be flushed out of the filter, and set the correct backwashing speed.

Before putting the filter into service it is necessary to backwash in order to check it for proper performance.

The maximum working pressure is up to 8 bar.

The filter is designed to withstand a maximum pressure of 10 bar and a differential pressure of up to 1 bar.

A pressure relief valve must be installed before the filtering installation if the pressure is not sufficiently under control. A differential-pressure switch must be installed over the filter in order to prevent the filter bottom from being overloaded.



Subject to changes and/or improvements

Operation:

Normal operating conditions are achieved when the pressure loss across a clean filter is less than 0.2 bar.

When the pressure loss exceeds 0.2 bar, the filter is partially clogged or the flow is far too high. Backwashing is required when the differential pressure has increased by 0.4-0.6 bar.

Check the differential pressure across the filter by measuring the differential pressure with the installed pressure gauges.

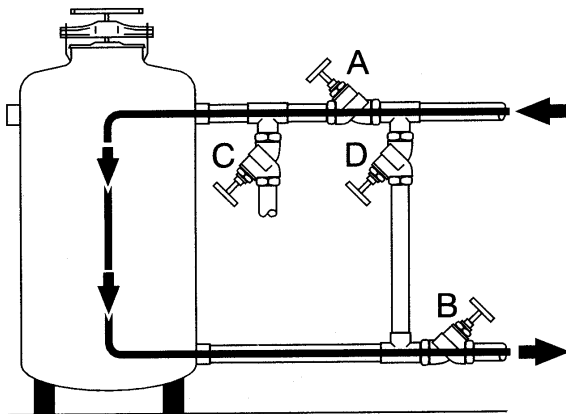

Filtration

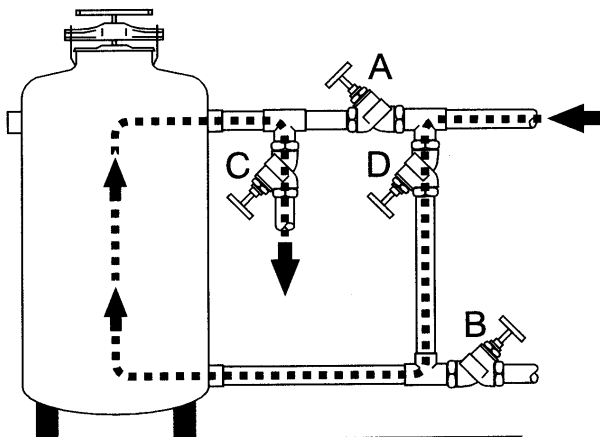

Backwashing

Automatic backwashing using a controller or computer is recommended.

For recommended capacities, see the table on the next page.

Backwash at the proper flow during 3-5 minutes.

Do not open the filter cover and do not tighten it while the filter is being used or under pressure.

Flushing:

The filter must be backwashed regularly as determined by the degree of soiling of the water and the amount of filtered water. During normal filtration, valves A and B will be open, whereas valves C and D will be closed. Valve C must be adjustable in order to be able to set the backwash capacity correctly.

- a. Close valves A and B and then open valves C and D. Backwash for 3-5 min.
- b. Thereupon, first close valve D and then C, and open valves A and B.

The filter is now clean and operating again.

Periodic cleaning:

Stop the flow to the filter. Close the valves of the filter inlet and outlet.

Let the pressure in the filter escape and open the filling hatch.

Inspect the height and the degree of soiling of the sand.

When the charge is no longer effective (short service time, too much coagulation, rubbed off), replace the filter-medium charge (see "changing the filter-medium charge").

Backwash the filter at the beginning and the end of a season.

Disinfection:

At the end of seasons or when changing crops it is recommended to disinfect the filter with chlorine (e.g. NaOCl) in a concentration of 80 to 100 ppm for 30 minutes at rest, followed by thorough backwashing for at least 5 minutes.

When on account of seasonal or crop changes the filter will be out of service, it can be drained after having been disinfected and be left in a dry condition until being used again.

Before putting the filter into operation again, it needs to be redisinfectated as described above.

Instruction Manual

Sand/media Filter Series 4000



Changing the filter-medium charge:

Change the charge when it is no longer effective.
 Close all valves and release the pressure in the filter.
 Open the filling hole on top of the filter.
 Open the service cover on the side of the filter and drain all water.
 Remove the charge from the filter through the service holes on the side of the filter.
 Thoroughly clean the filter inside with clean water.
 Inspect the mushroom diffusers and the double bottom of the filter.
 Check the protective coating and repair any damage immediately.
 Carefully close the service covers on the side.
 Charge the filter through the filling hole and then follow the instructions, see "Installation".

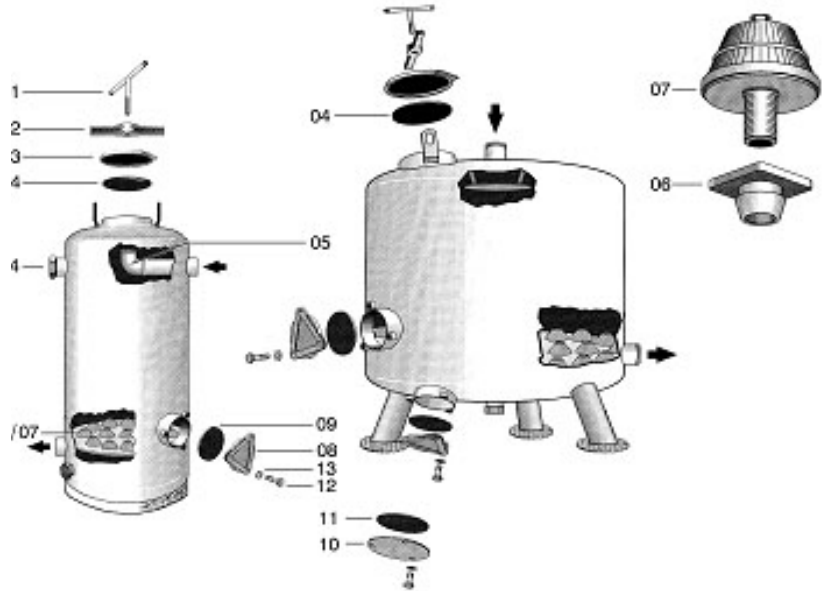

Parts drawing

Type	Unit	4121	41615	4202	4242	43025	4363	4425	4484	46041
Diameter	Inch	12"	16"	20"	24"	30"	36"	42"	48"	60"
Capacity	m ³ /h	3.5	6.5	10	14	22	32	45	58	90
Connection	inch	1"	1.5"	2"	2"	2.5"	3"	3"	4"	4"
Charge of sand	kg	50	75	125	200	250	375	500	650	1000
Backwashing appr.*	m ³ /h	3	6	9	12	19	28	38	50	75

*based on a charge of sand; for other media, consult installation firm!

Notes:

Install an UDI® screen filter as a safety component after a media filter.
 In the event of calamities, this will prevent damage to installations and/or devices downstream.
 In view of ongoing improvements, we reserve the right to change specifications without prior notice.

Maintenance:

Each filter comes with these installation, operating and maintenance instructions.
 Apply a film of grease on the thread of the spindle of the handle (01).
 Any damage to the protective coating of the filter must be repaired immediately.
 Before applying the protective paint, the damaged spot must be cleaned properly using a steel wire brush.

Instruction Manual

Sand/media Filter Series 4000

General instructions:

The Series 9000 filters are horizontally positioned cylinders with connections on one side. Two rows of mushroom diffusers are mounted on a low-lying pipe located in the filter bed.

Operation:

All operating instructions are the same as for the 4000 Series. **Do not open the filter cover and do not tighten it while the filter is being used or under pressure!**

Installation:

Place the media filter in an exactly horizontal position on a solid ground so that it is easily accessible for service and maintenance. For further installation, see Series 4000 sand/media filters.

Maintenance:

Each filter comes with these installation, operating and maintenance instructions. Apply a film of grease on the thread of the bolts. Any damage to the protective coating of the filter must be repaired immediately. Before applying the protective paint, the damaged spot must be cleaned properly using a steel wire brush.

Note:

In view of ongoing improvements, we reserve the right to change specifications without prior notice.

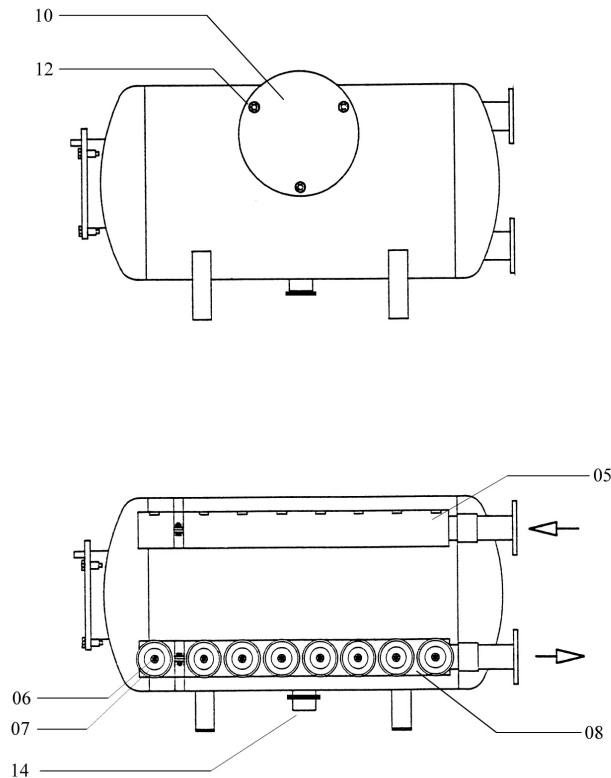

Parts drawing

Type	Unit	9202	9243
Diameter	Inch	20"	24"
Capacity	m ³ /h	22	32
Connection	Inch	2.5"	3"
Charge of sand	kg	150	250
Backwashing appr.*	m ³ /h	19	28