

Instruction Manual

Plastic Cyclone Filters



General instructions:

This filter has been designed and made to meet the highest requirements as to quality and finish. This filter separates sand and similar solids from the water at a small pressure loss and an efficiency better than 95%. By using a (type 620) filter gauze, water filtration is enhanced even further.

Installation:

These filters must be installed in a vertical position.

Use teflon tape on threaded connections. Water inlet and outlet are clearly indicated by the arrows.

The flush valve must be located at the bottom of the filter. A pressure relief valve must be mounted before the filter if the pressure is not sufficiently under control.

The filter is designed to withstand a maximum pressure of 10 bar.

Do not open the filter while under pressure.

Operation:

Normal operating conditions are achieved when the capacity is within the values indicated. The general rule is that the efficiency increases as the water velocity, i.e. the capacity, increases. The accumulated sand/dirt must be drained off regularly by opening the drain tap. The frequency depends on the amount of sand/dirt being filtered from the water. In the case of high concentrations, dirt can be drained off using an electric valve and timer.

Periodic cleaning (type 520):

Stop the flow to the filter.
Open the flush valve to let pressure and water escape. Open the filter and check the inside of the cyclone. Clean the filter cover inside if necessary. Place the filter cover back on the filter body and check to ensure that the cover rubber has been properly placed. Fasten the cover using the cover clamp.

Periodic cleaning (type 620):

Recommended cleaning of the filter and checking of the filter element: every 2 weeks or when the differential pressure is 0.5 bar or higher.

Stop the flow to the filter.

Open the drain valve to let pressure and water escape. Open the filter and remove the filter element by loosening the pressure nut on the holder. Thoroughly clean the element with clean water, using a brush to remove dirt particles from the gauze (NEVER USE A STEEL WIRE BRUSH).

If the dirt particles cannot be removed from the element with a hair-fibre brush, dip the element into an acid/alkaline solution. Wait a few minutes for the solution to have its effect and then clean the element thoroughly.

After cleaning, proceed to assemble as follows: Check to ensure the filter element is intact and not damaged. Check whether the rubbers have been placed properly. Carefully place the filter element back into the filter body on the holder and secure the pressure nut finger-tight. Place the filter cover back on the filter body and check whether the cover rubber has been placed properly. Fasten the cover using the cover clamp.

Maintenance:

Each filter comes with these installation, operating and maintenance instructions. Regularly check the pressure loss across the filter so as to be aware of the condition of the filter element.

In view of ongoing improvements, we reserve the right to change specifications without prior notice.



Parts drawing:

2" Zandafscheider

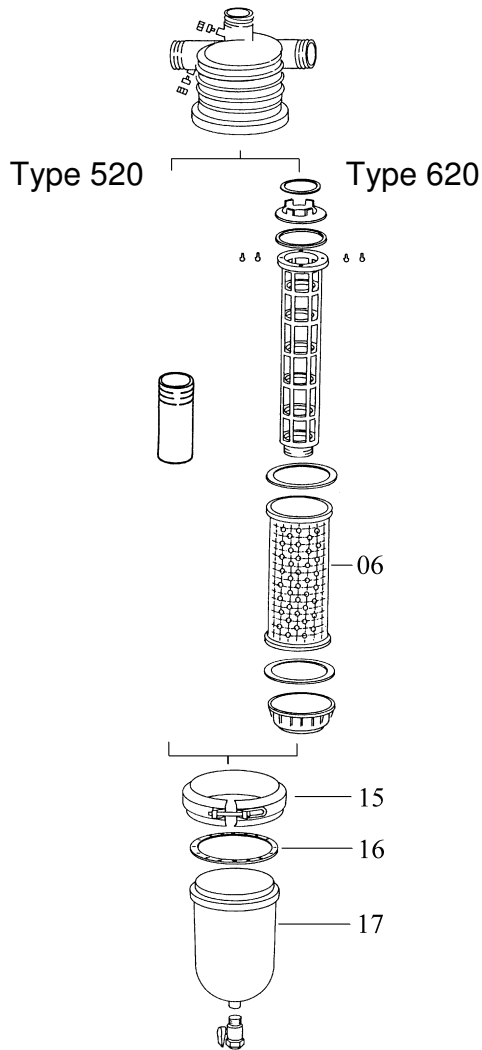

Pressure losses at plastic cyclone filter:

Type	Unit	7U520D	7U620D
Connection	inch	2"	2"
Capacity	m ³ /h	10-25	5-25
Pressure loss	mwc	1.5-10	0.5-3