

Instruction Manual

Plastic Valves



Safety above all:

BERMAD is of the opinion that the people working with and/or in the vicinity of its products must be given the highest priority. Before starting any procedure, you must have read and understood completely the relevant instruction. If you do not understand it completely, you need to consult the proper authority before taking any action.

General instructions:

The Series 200 plastic valves have been designed to meet the highest quality standards. The maximum allowable pressure is 10 bar, take measures when the pressure is not under control. The valve can be mounted both in a horizontal and in a vertical position.

Installation:

Ensure stress-free installation of the valve in the pipe system which must be sufficiently supported and protected against mechanical forces. Provide the fitted connections with enough packing material, such as teflon tape, and tighten with the proper force (plastic). Secure the electric connections (low-voltage current) with cable connectors and conceal the cables safely, as best one can while ensuring they are kept dry.

Operation:

Dirty water can clog the internal water passages. A dirty-water filter is needed, or use an adapted valve. The valves can be closed and/or opened manually, electrically or by a control valve. **Before removing** the solenoid, navaton, valve cover or complete valve, **ensure that the installation has been depressurized**.

Maintenance:

Periodically check the installation for pressure using an installed pressure gauge at the point(s) where the valve(s) is (are) included. Be alert to leaks, and carefully check supports and cable connections, taking corrective measures immediately if found defective.

In view of ongoing improvements, we reserve the right to change specifications without prior notice.

General information:

All valves have been factory-tested. Used in an installation that meets the required conditions, the valve will operate correctly.



UVAR

Subject to changes and/or misprints

Instruction Manual

Plastic Valve Series 200 - 3/4" - 1" - 1 1/2" - 2"



Electric valve installation instructions:

- 1) Leave sufficient room around the valve to allow for adaptations or maintenance work.
- 2) Thoroughly flush the pipes to remove dirt and deposits.
Neglecting this may adversely affect the valve's operation.
- 3) Install the valve so that the arrow on the body corresponds to the actual direction of flow.
- 4) Check whether the electric current specifications on the solenoid correspond to the power supply facilities available in order to prevent damage to the solenoid.
- 5) After installation, carefully check all accessories, tubing and fittings for any damage and repair this immediately.

Electric valve troubleshooting:

<u>SYMPTOM</u>	<u>CAUSE</u>	<u>REMEDY</u>
Valve fails to open	no electric current insufficient inlet pressure	check power supply facilities check water-pressure facilities
	Solenoid: - core stuck - connections clogged - no response – “no click”	check and clean core check and clean connections test the solenoid, replace if necessary, check whether the power supply corresponds to the current as specified on the solenoid.
	Diaphragm is leaking	replace diaphragm
Valve fails to close	dirt around the needle (2w) in-line strainer is closed (3w)	remove, clean and use a filter. remove and clean the in-line strainer
	Solenoid: - continues to be energized - connections clogged	de-energize solenoid check and clean connections
	Dirt stuck under diaphragm	open valve and remove dirt check diaphragm for damage



Instruction Manual

Plastic Valve Series 200



3/4" - 1" valve 2w:

Specific parts:

2S21007G05	Diaphragm assembly for 3/4" - 1" valve 2w (with hole)
-	Solenoid 2w

3/4" - 1" valve 3w:

Specific parts

2S21107G05	Diaphragm assembly for 3/4" - 1" valve 3w
-	Solenoid 3w
-	In-line filter/hose

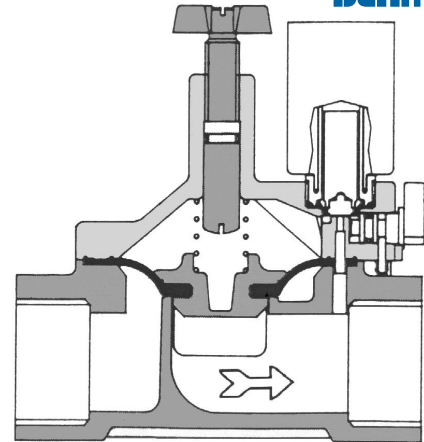

1 1/2" - 2" valve 2w:

Specific parts:

2S21015G17	Needle 2w
2S21015G05	Diaphragm assembly 2w
2S21015G08	Bolt and nut for diaphragm assembly 2w
-	Solenoid 2w

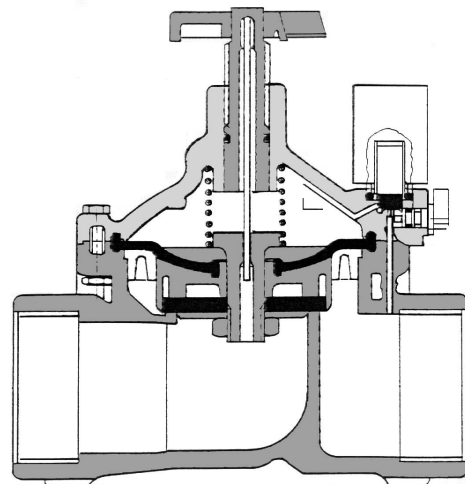

1 1/2" - 2" valve 3w:

Specific parts:

2S21115G05	Diaphragm assembly 3w
2S21115G08	Bolt and nut for diaphragm assembly 3w
-	Solenoid 3w
-	In-line filter/hose

In 3w version, not affected by soiled water due to control loop provided with self-cleaning filter

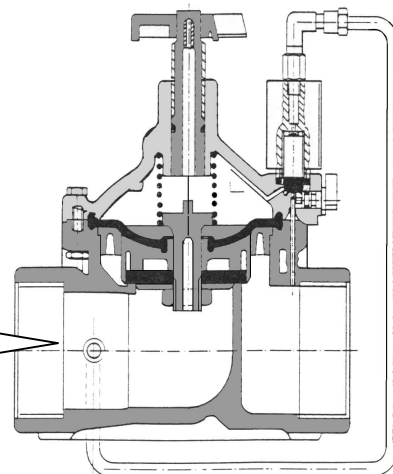
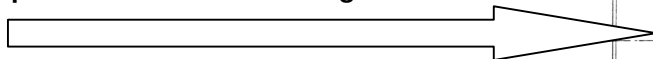

Instruction Manual

Plastic Valve Series 200 – 1½” – 2”

Valve 3w NO

Specific parts:

- | | | |
|-----|-----------|---------------------|
| 01) | 2U209..G | Valve HM |
| 02) | - | Solenoid base |
| 03) | 2S2000050 | Solenoid 3w NC |
| 04) | - | In-line filter/hose |

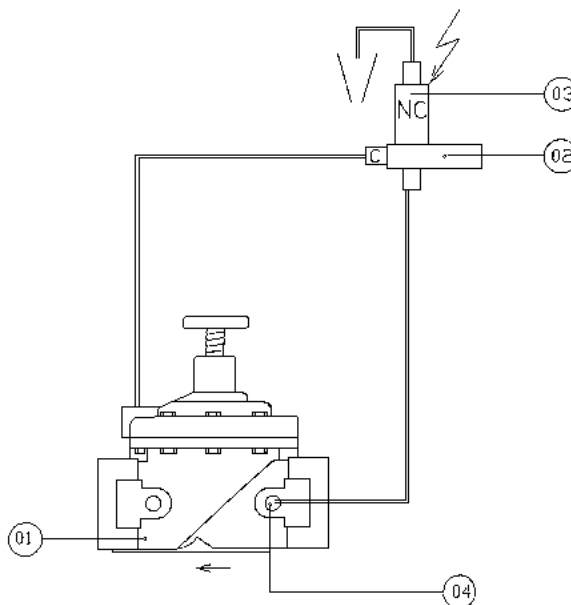

Specific parts:

- | | | |
|-----|-----------|--|
| 01) | 2U209..G | Valve HM |
| 02) | - | In-line filter/hose |
| 03) | 2S2000003 | Restriction orifice stainless steel 1 mm |

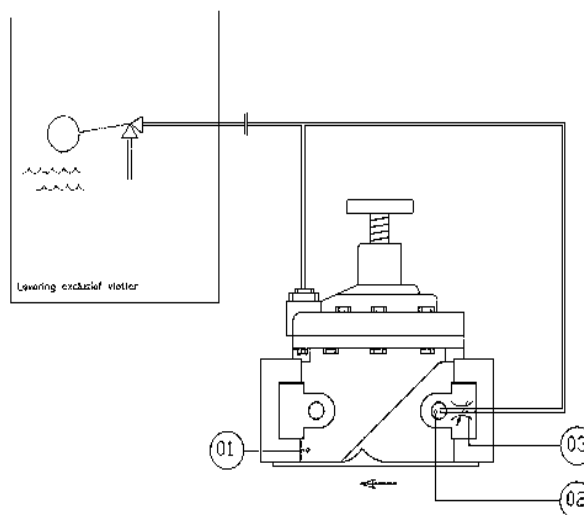

The Bermad 200 Series valves are available in both globe and angle patterned versions.

It is possible to combine functions and design variations on the same valve.

Instruction Manual

Plastic Valve Series 200 – 1½” – 2”

Relief valve 3w

Specific parts:

- | | | |
|-----|---------|---------------------|
| 01) | 2U09..G | Valve HM |
| 02) | 2U2PC10 | Navaton 3w |
| 03) | - | In-line filter/hose |

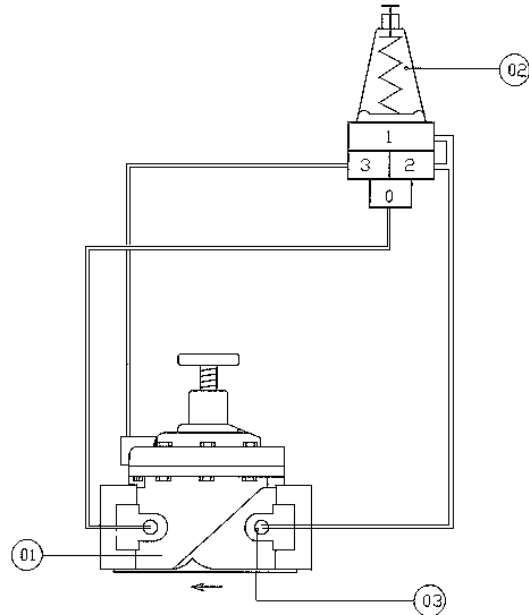

Pressure-reducing valve 2w 24V

Specific parts:

- | | | |
|-----|-----------|---------------------|
| 01) | 2U209..G | Valve HM |
| 02) | 2S2000050 | Solenoid base |
| 03) | - | Solenoid 2w |
| 04) | 2U2PC20A | Navaton 2w |
| 05) | - | In-line filter/hose |

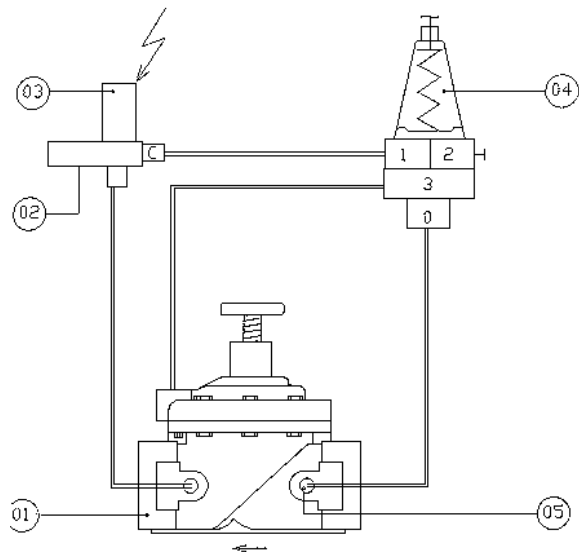

The Bermad 200 Series valves are available in both globe and angle patterned versions.

It is possible to combine functions and design variations on the same valve.