

Instruction Manual

BAR Water Meters



General instructions:

Installing a water meter correctly increases its accuracy and life span. All turbine water meters are sensitive to turbulent conditions caused by pumps, diameter reduction, bends, T-pieces, valves, etc. The water meter must be installed at a sufficient distance from the above parts and components.

Installation:

All water meters must be installed in a straight pipe – having the same diameter as the nominal diameter of the water meter – at a minimum distance of 5x the diameter before and 3x the diameter after the water meter. The globe water meters can be installed without the required pipe length. Prior to installation, the pipe must be flushed to remove coarse dirt matter.

The water meter must be completely filled with water during measuring. If the water contains dirt (harmful to the water meter), install a filter before the water meter. If there is a risk of water flowing back, install a quick-acting (mechanical) check valve.

Operation:

To ensure normal operating conditions, the quantity of water flowing through the water meter should correspond as closely as possible to the nominal capacity. In this respect, bear in mind the installation instructions previously cited. Be alert to the maximum working pressure!

Do not detach or open the water meter while under pressure!

Maintenance:

All water meters come with these installation and maintenance instructions. Check the water meter for damage annually. Any damage to the protective coating must be repaired immediately. Before applying the protective paint, the damaged spot must be thoroughly cleaned using a steel wire brush. In view of ongoing improvements, we reserve the right to change specifications without prior notice.

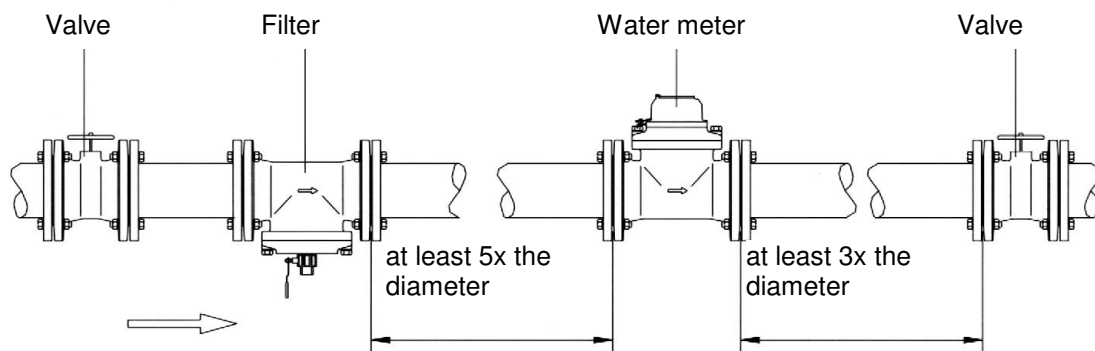

General information:

- All water meters are factory-calibrated. (test certificate available as an option)
- The life of the water meters greatly depends on the water quality and use. The water meters must be reconditioned according to the regulations of the local water board/water-management authority. We recommend reconditioning at least within 5 years or 100000m³ after installation.
- All water meters can be installed both horizontally and vertically.
- For normal use according to the instructions provided, the error tolerance is